

# ConTempo 150-250-350

RVP350 MAX400W-E40 S

Symmetrical

The Contempo floodlight has a registered design that blends well with contemporary outdoor environments. It has a rugged pressure die-casted aluminum housing with corrosion resistant powder coating. Contempo also features an integrated energy saving copper ballast, electronic semi-parallel ignitor and capacitor. The unit has passed rigorous tests for dust and water ingress protection.

## Product data

General Information	
Number of light sources	1 pc
Lamp family code	-
Lamp power	400 W
Cap-Base	E40 [ E40]
Kombipack	-
Compensation circuit	-
Gear	E [ Empty, without gear]
Country version	NO [ Norway]
Optic type outdoor	Symmetrical
Operating and Electrical	
Maximum lamp power	Max. 400 W
Ignitor	-

Approval and Application	
Ingress protection code	IP65 [ Dust penetration-protected, jet-proof]
Product Data	
Full product code	911401054380
Order product name	RVP350 MAX400W-E40 S
EAN/UPC - Product	6923828621261
Order code	911401054380
Numerator - Quantity Per Pack	1
Numerator - Packs per outer box	1
Material Nr. (12NC)	911401054380
Net Weight (Piece)	8.999 kg

## ConTempo 150-250-350

### Dimensional drawing

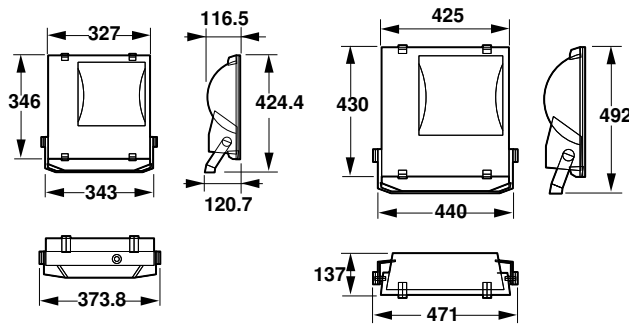

ConTempo rvp150/250/350

